

Novel Coating to Prevent Corrosion of Coiled Tubing Bias Welds

Yunhao Li, Quality Tubing

ICoTa Canada Roundtable
Calgary, AB
October 24, 2018

Agenda

- Background
 - Coiled Tubing (CT)
 - Physical Vapor Deposition (PVD)
 - How would this work with CT
- Experimental Tests
 - Test Plan
 - Results
- Apparatus Design & Acceptance Test
- Next Steps



Background

- Coiled Tubing

- Coiled tubing work strings are made from high strength low alloy steel strips welded end-to-end (plasma arc weld; we call it the bias weld) and seam welded into tubing
- Tubing is pressurized and used for intervention and completion operations
- Tubing is bent plastically while under pressure
- Primary failure mechanism is low cycle fatigue (LCF)



Background

- Coiled Tubing

- Shale plays have led to a new type of corrosion mechanism

- Microbiologically Induced Corrosion (MIC). Why?

- Recirculated fluids
 - High temperature
 - Friction Reducer

- But don't rule out

- H_2S
 - CO_2
 - Uninhibited acid

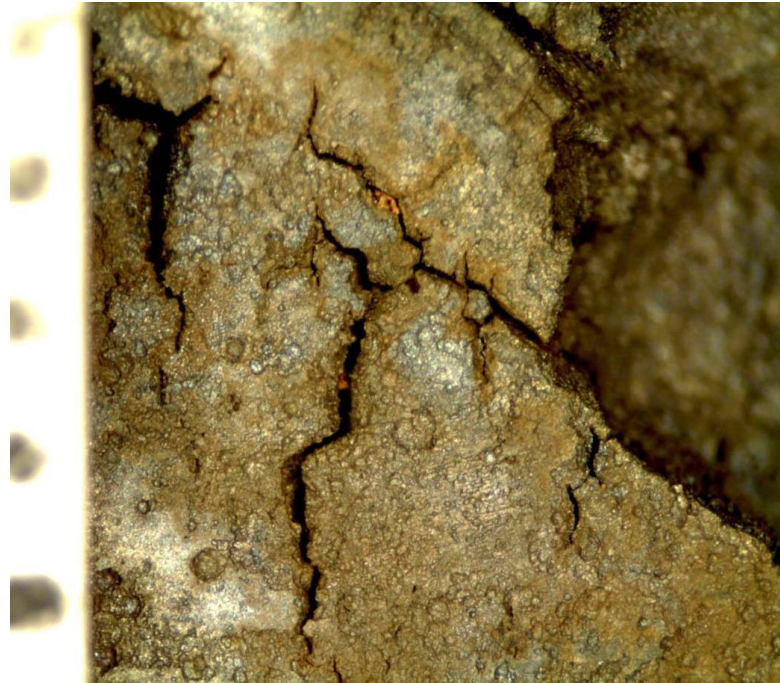

Background

- Physical Vapor Deposition (PVD)

- The target and substrate are placed within a vacuum chamber
- The target is ionized to become a plasma
- A thin film is deposited onto the substrate

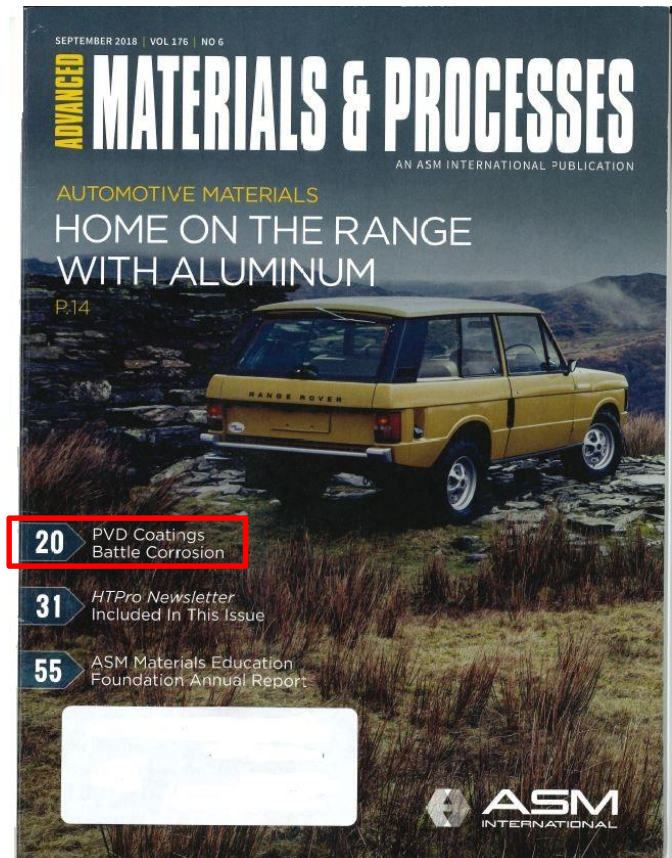
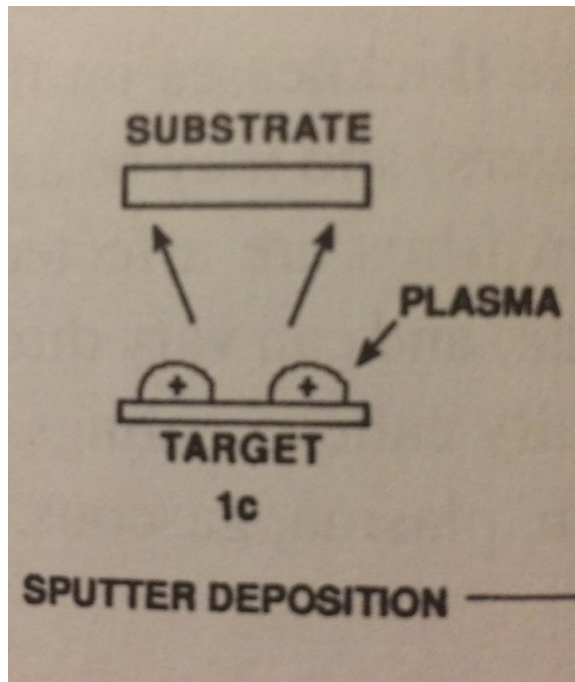

Background – How would this apply to CT?

- The corrosion is not a manufacturing defect
 - Exists primarily on the tubing ID due to corrosive fluids
 - Shale plays generate the worst corrosive fluids

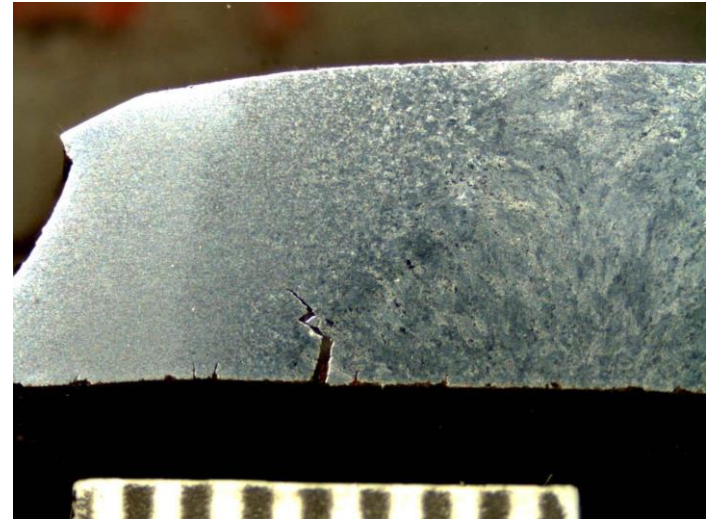

Background – How would this apply to CT?

To avoid MIC:

- Identify and kill bacteria
- Minimize inhomogeneity across weldment
 - Multiple conceptual solutions exist
 - Secondary thermal processing mitigates but does not fully resolve the issue
- If aqueous corrosive solutions do not wet the surface, there will be no corrosion

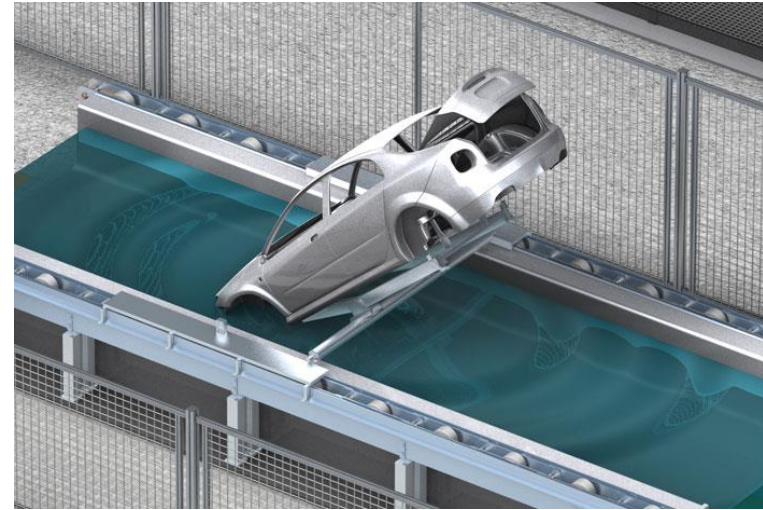

Background – How would this apply to CT?

- We can locally coat the strip joining weld (weld cap)
- The opportunity:
 - Mitigating corrosion issue can improve CT performance reliability
 - An industry-leading vendor licenses to NOV/QT and transfers the technology
 - Good bond strength, thin film
- Why have we not coated in the past?
 - Coatings have adhesion issues

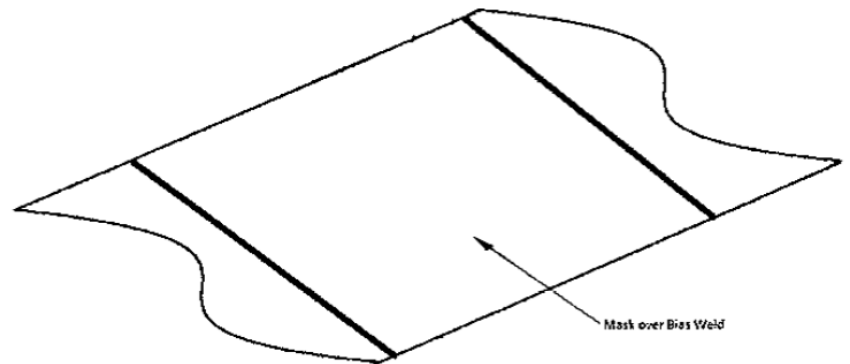
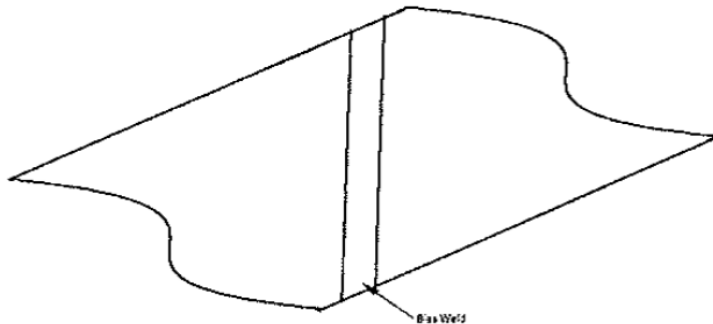

Experimental Tests

- StageGate Program Developed
- Goals: Prove the concept and select a coating/thickness
 - 1st Test: Coat our steel
 - *Bend Test*
 - *Acid Exposure*
 - 2nd Test: Coat our steel and make tubing
 - *Make Tubing*
 - *Low Cycle Fatigue Testing*
 - 3rd Test: Apparatus Installation



Experimental Test Results

- 1st Test: Bend Test
 - Tested 10 different coating/thickness variations
 - Only one cracked

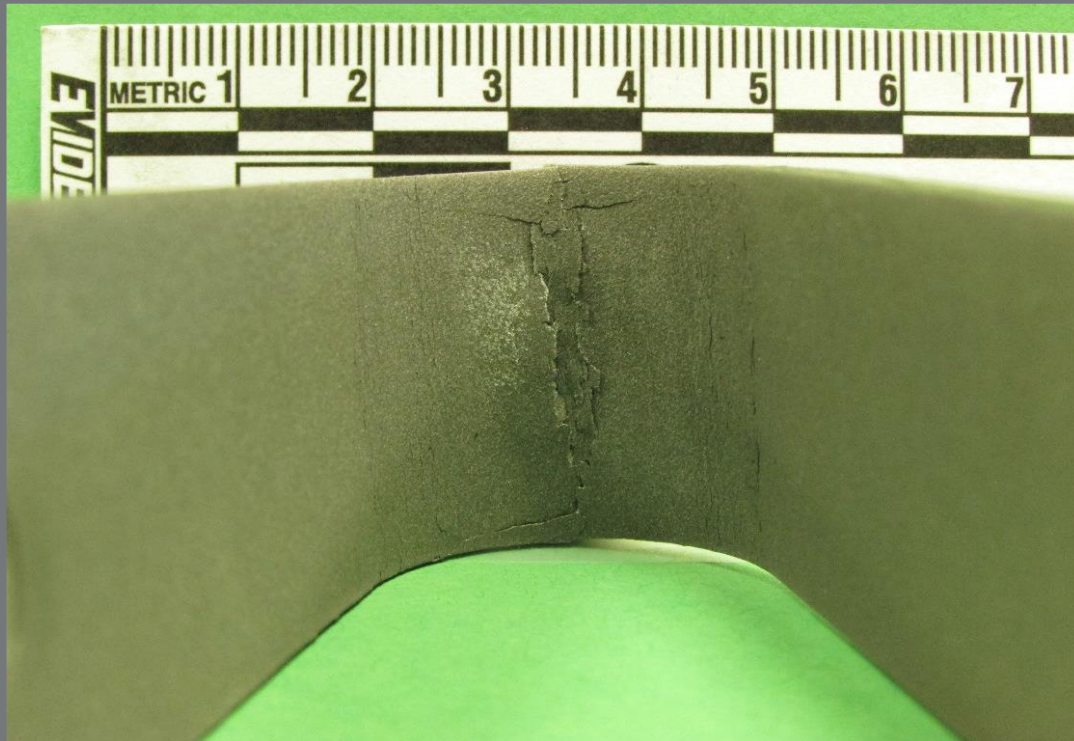

Experimental Test Results

- 1st Test: Acid Exposure
 - Tested 4 different coatings types
 - Immersed in 15% uninhibited HCl for 7 days
 - Only one coating resisted the acid



Experimental Test Results

- 2nd Test: Make Tubing and Test for Low Cycle Fatigue



Experimental Test Results

- Weld seam not coated
- 0 out of 102 corrosion pitting failure at bias weld were also at seam



Apparatus Design

- Testing program successful
- We need to build a working prototype
- The challenge: how to achieve a vacuum with our geometry

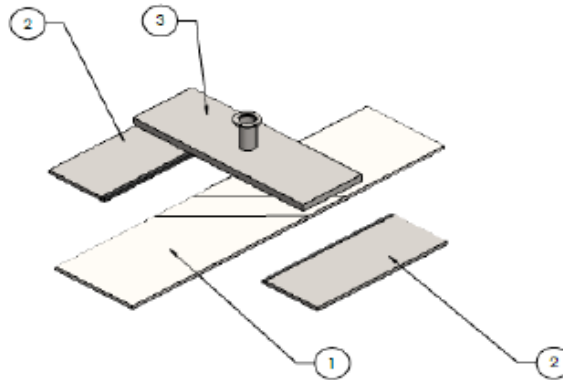
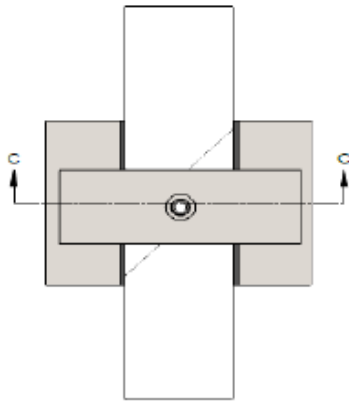

Apparatus Acceptance Test



Next Steps

- Working prototype in mid-Q4 2018
- To field trial on 2-3/8", 2-5/8" in Q4 2018
- Field reports in Q1 2019; SPE paper in March 2019



Quality Tubing

NOV Completion &
Production Solutions